



ATHLETIC FACILITIES

HIGH JUMP LANDING AREAS

- 1250 High Jump Landing Area
- 1300 High Jump Landing Area
- 1325 High Jump Landing Area
- 1360 High Jump Landing Area
- 1380 High Jump Landing Area
- 1390 High Jump Landing Area

MODEL 1250 5.02M X 3.04M X 66CM
(16'6" X 10' X 26")



Lifetime Guarantee: All handles and straps. Handles are 2 inch 3500 T.C. nylon webbing encased in 21 oz. vinyl knife coated fabric. Handles are sewn to side of pit below zipper flap. Triple reinforced.

15 year Guarantee: On seams and hems against defective material and workmanship. If problems occur during normal use, UCS will repair at no charge or provide materials to repair the area applicable to Top Pad mesh, or Vinyl on base units.

UCS Vinyl Material: Sides and Bottoms of all units manufactured out of 21oz knife coated vinyl composed of 5 oz. 840 denier nylon with a 23x23 construction and 16oz of liquid coated urethane that is spread over one side of the nylon material. Results in a 37 oz equivalent that has the highest tear strength in the industry and the most vinyl on the exposed side.

Seams and hems: Double stitched, double folded and double stitched again with high tenacity 232 polyester thread, with at least 5 stitches to the inch and no more than 6 stitches

Foam Construction: New honeycomb urethane foam combines three densities and three compressions in unique lattice configuration.

VTX 1000 System: Exclusive 8" wide Velcro with a 21 oz knife coated vinyl backing holds base units and front units together. Takes stress off the Top Pad.

Spike resistant breather fabric: 1000 denier 14 x 12 PVC extruded fabric.

2 inch Foam Top Pad is Standard: Holds entire pit securely in place. Provides safe comfortable landings. Prevents landing between the units.

Safety Cut-Outs: All UCS High Jump Pits have cut-outs for High Jump Standards.

Colors Available: Red, Green, Blue, Purple, Gold, Maroon, Orange, Burnt Orange, Magenta, and Black

Meets or exceeds all NFHS Regulations.

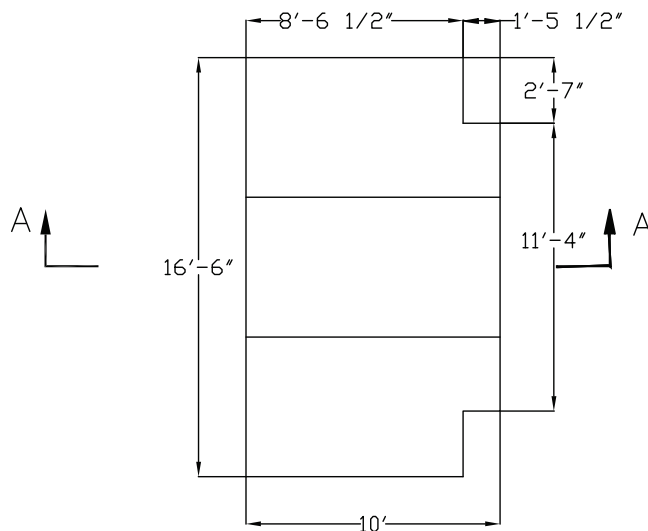
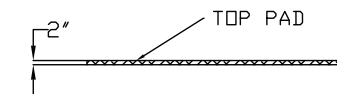

Vinyl Mesh Colors for Landing Areas, Weather Covers, and Base Protection



MODEL 1300 5.26M X 3.04M X71CM
(17'6" X 10' X 28")

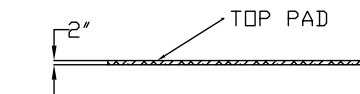

SECTION A-A

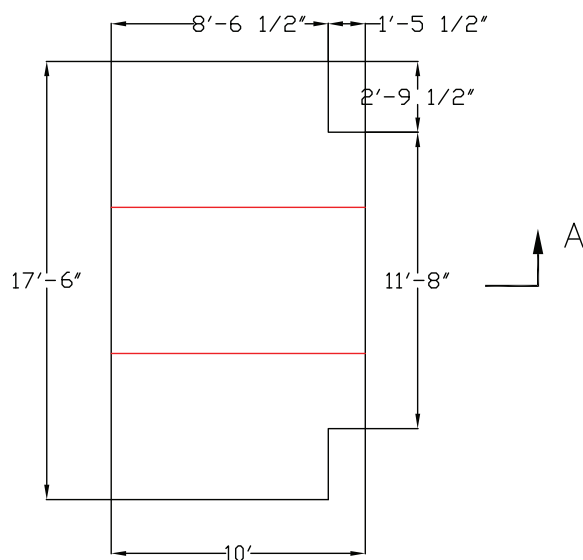

Lifetime Guarantee: All handles and straps. Handles are 2 inch 3500 T.C. nylon webbing encased in 21 oz. vinyl knife coated fabric. Handles are sewn to side of pit below zipper flap. Triple reinforced.

15 year Guarantee: On seams and hems against defective material and workmanship. If problems occur during normal use, UCS will repair at no charge or provide materials to repair the area applicable to Top Pad mesh, or Vinyl on base units.

UCS Vinyl Material: Sides and Bottoms of all units manufactured out of 21oz knife coated vinyl composed of 5 oz. 840 denier nylon with a 23x23 construction and 16oz of liquid coated urethane that is spread over one side of the nylon material. Results in a 37 oz equivalent that has the highest tear strength in the industry and the most vinyl on the exposed side.

Seams and hems: Double stitched, double folded and double stitched again with high tenacity 232 polyester thread, with at least 5 stitches to the inch and no more than 6 stitches

Foam Construction: New honeycomb urethane foam combines three densities and three compressions in unique lattice configuration.

VTX 1000 System: Exclusive 8" wide Velcro with a 21 oz knife coated vinyl backing holds base units and front units together. Takes stress off the Top Pad.

Spike resistant breather fabric: 1000 denier 14 x 12 PVC extruded fabric.

2 inch Foam Top Pad is Standard: Holds entire pit securely in place. Provides safe comfortable landings. Prevents landing between the units.

Safety Cut-Outs: All UCS High Jump Pits have cut-outs for High Jump Standards.

Colors Available: Red, Green, Blue, Purple, Gold, Maroon, Orange, Burnt Orange, Magenta, and Black

Meets or exceeds all NFHS Regulations.

VinylMeshColorsforLandingAreas,WeatherCovers,andBaseProtectionPads



MODEL 1325 6.01M X 3.04M X 71CM
(20' X 10' X 28")

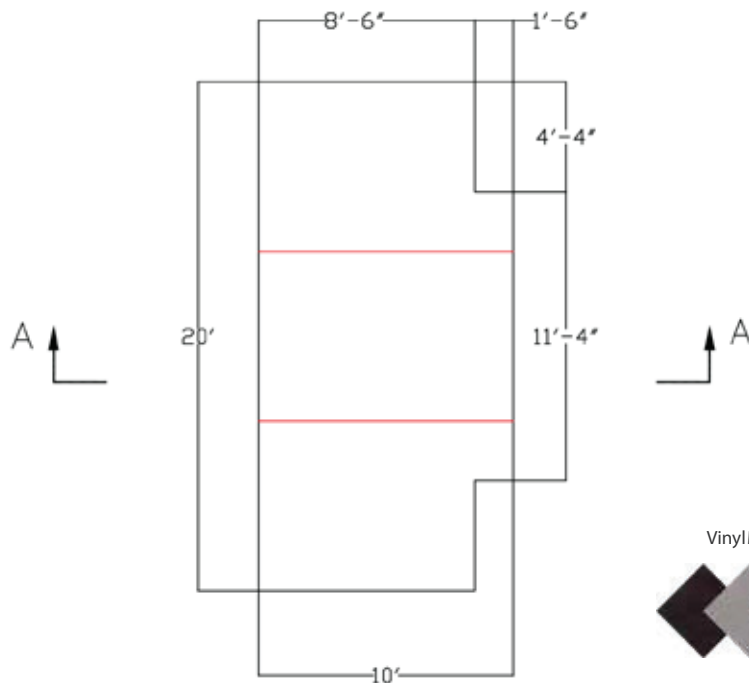

Lifetime Guarantee: All handles and straps. Handles are 2 inch 3500 T.C. nylon webbing encased in 21 oz. vinyl knife coated fabric. Handles are sewn to side of pit below zipper flap. Triple reinforced.

15 year Guarantee: On seams and hems against defective material and workmanship. If problems occur during normal use, UCS will repair at no charge or provide materials to repair the area applicable to Top Pad mesh, or Vinyl on base units.

UCS Vinyl Material: Sides and Bottoms of all units manufactured out of 21oz knife coated vinyl composed of 5 oz. 840 denier nylon with a 23x23 construction and 16oz of liquid coated urethane that is spread over one side of the nylon material. Results in a 37 oz equivalent that has the highest tear strength in the industry and the most vinyl on the exposed side.

Seams and hems: Double stitched, double folded and double stitched again with high tenacity 232 polyester thread, with at least 5 stitches to the inch and no more than 6 stitches

Foam Construction: New honeycomb urethane foam combines three densities and three compressions in unique lattice configuration.

VTX 1000 System: Exclusive 8" wide Velcro with a 21 oz knife coated vinyl backing holds base units and front units together. Takes stress off the Top Pad.

Spike resistant breather fabric: 1000 denier 14 x 12 PVC extruded fabric.

2 inch Foam Top Pad is Standard: Holds entire pit securely in place. Provides safe comfortable landings. Prevents landing between the units.

Safety Cut-Outs: All UCS High Jump Pits have cut-outs for High Jump Standards.

Colors Available: Red, Green, Blue, Purple, Gold, Maroon, Orange, Burnt Orange, Magenta, and Black

Meets or exceeds all NFHS Regulations.

Vinyl Mesh Colors for Landing Areas, Weather Covers, and Base Protection Pads



MODEL 1360 6.01M X 3.65M X 71CM
(24'4" X 12' X 28")

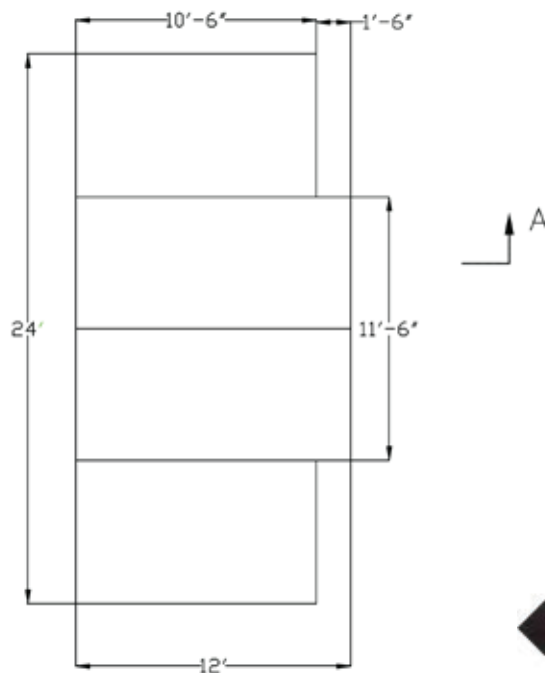
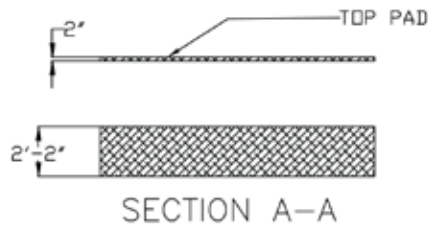

Lifetime Guarantee: All handles and straps. Handles are 2 inch 3500 T.C. nylon webbing encased in 21 oz. vinyl knife coated fabric. Handles are sewn to side of pit below zipper flap. Triple reinforced.

15 year Guarantee: On seams and hems against defective material and workmanship. If problems occur during normal use, UCS will repair at no charge or provide materials to repair the area applicable to Top Pad mesh, or Vinyl on base units.

UCS Vinyl Material: Sides and Bottoms of all units manufactured out of 21oz knife coated vinyl composed of 5 oz. 840 denier nylon with a 23x23 construction and 16oz of liquid coated urethane that is spread over one side of the nylon material. Results in a 37 oz equivalent that has the highest tear strength in the industry and the most vinyl on the exposed side.

Seams and hems: Double stitched, double folded and double stitched again with high tenacity 232 polyester thread, with at least 5 stitches to the inch and no more than 6 stitches

Foam Construction: New honeycomb urethane foam combines three densities and three compressions in unique lattice configuration.

VTX 1000 System: Exclusive 8" wide Velcro with a 21 oz knife coated vinyl backing holds base units and front units together. Takes stress off the Top Pad.

Spike resistant breather fabric: 1000 denier 14 x 12 PVC extruded fabric.

2 inch Foam Top Pad is Standard: Holds entire pit securely in place. Provides safe comfortable landings. Prevents landing between the units.

Safety Cut-Outs: All UCS High Jump Pits have cut-outs for High Jump Standards.

Colors Available: Red, Green, Blue, Purple, Gold, Maroon, Orange, Burnt Orange, Magenta, and Black

Meets and exceeds all NFHS AND NCAA Regulations.

Vinyl Mesh Colors for Landing Areas, Weather Covers, and Base Protection Pads



MODEL 1380 6.10M X 4.01M X 66CM
(20' X 13'2" X 26")

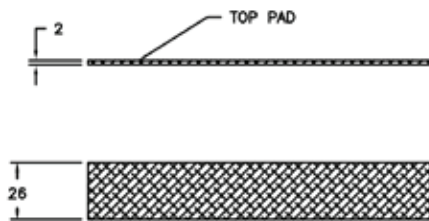

SECTION A-A

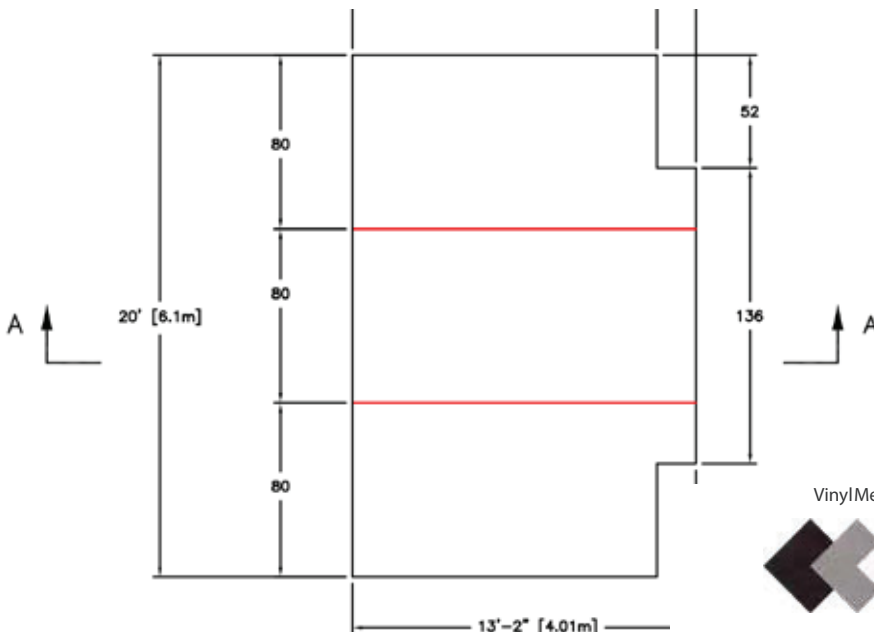

Certificate: E-04-0389

Lifetime Guarantee: All handles and straps. Handles are 2 inch 3500 T.C. nylon webbing encased in 21 oz. vinyl knife coated fabric. Handles are sewn to side of pit below zipper flap. Triple reinforced.

15 year Guarantee: On seams and hems against defective material and workmanship. If problems occur during normal use, UCS will repair at no charge or provide materials to repair the area applicable to Top Pad mesh, or Vinyl on base units.

UCS Vinyl Material: Sides and Bottoms of all units manufactured out of 21oz knife coated vinyl composed of 5 oz. 840 denier nylon with a 23x23 construction and 16oz of liquid coated urethane that is spread over one side of the nylon material. Results in a 37 oz equivalent that has the highest tear strength in the industry and the most vinyl on the exposed side.

Seams and hems: Double stitched, double folded and double stitched again with high tenacity 232 polyester thread, with at least 5 stitches to the inch and no more than 6 stitches

Foam Construction: New honeycomb urethane foam combines three densities and three compressions in unique lattice configuration.

VTX 1000 System: Exclusive 8" wide Velcro with a 21 oz knife coated vinyl backing holds base units and front units together. Takes stress off the Top Pad.

Spike resistant breather fabric: 1000 denier 14 x 12 PVC extruded fabric.
2 inch Foam Top Pad is Standard: Holds entire pit securely in place. Provides safe comfortable landings. Prevents landing between the units.

Safety Cut-Outs: All UCS High Jump Pits have cut-outs for High Jump Standards.

Colors Available: Red, Green, Blue, Purple, Gold, Maroon, Orange, Burnt Orange, Magenta, and Black

Meets and exceeds all NFHS AND NCAA Regulations.

MODEL 1390 7.31M X 4.01M X 71CM
(24' X 13' 2" X 28")

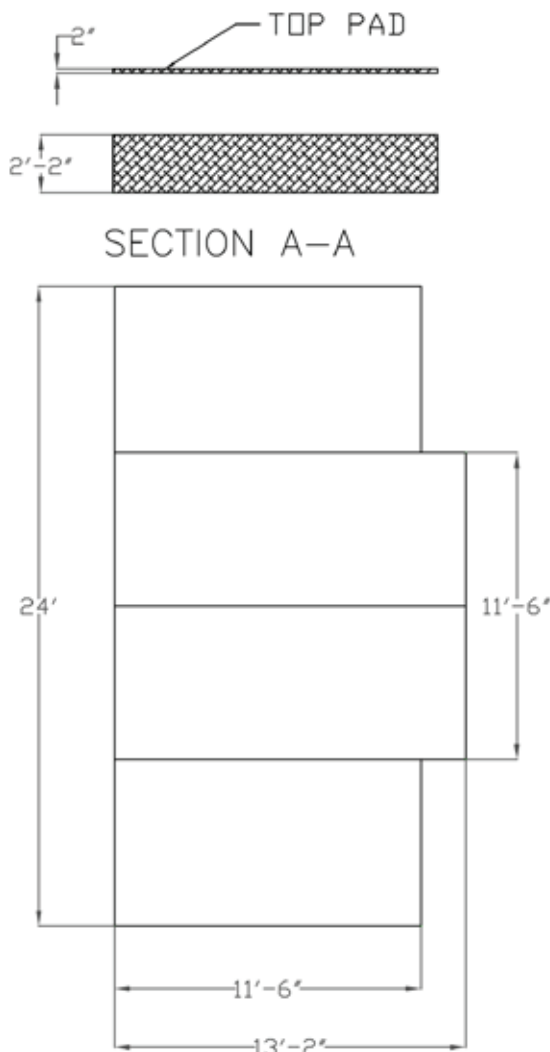

World Athletics Certificate: E-99-0072

Lifetime Guarantee: All handles and straps. Handles are 2 inch 3500 T.C. nylon webbing encased in 21 oz. vinyl knife coated fabric. Handles are sewn to side of pit below zipper flap. Triple reinforced.

15 year Guarantee: On seams and hems against defective material and workmanship. If problems occur during normal use, UCS will repair at no charge or provide materials to repair the area applicable to Top Pad mesh, or Vinyl on base units.

UCS Vinyl Material: Sides and Bottoms of all units manufactured out of 21oz knife coated vinyl composed of 5 oz. 840 denier nylon with a 23x23 construction and 16oz of liquid coated urethane that is spread over one side of the nylon material. Results in a 37 oz equivalent that has the highest tear strength in the industry and the most vinyl on the exposed side.

Seams and hems: Double stitched, double folded and double stitched again with high tenacity 232 polyester thread, with at least 5 stitches to the inch and no more than 6 stitches

Foam Construction: New honeycomb urethane foam combines three densities and three compressions in unique lattice configuration.

VTX 1000 System: Exclusive 8" wide Velcro with a 21 oz knife coated vinyl backing holds base units and front units together. Takes stress off the Top Pad.

Spike resistant breather fabric: 1000 denier 14 x 12 PVC extruded fabric. 2 inch Foam Top Pad is Standard: Holds entire pit securely in place. Provides safe comfortable landings. Prevents landing between the units.

Safety Cut-Outs: All UCS High Jump Pits have cut-outs for High Jump Standards.

Colors Available: Red, Green, Blue, Purple, Gold, Maroon, Orange, Burnt Orange, Magenta, and Black

Meets and exceeds all NFHS AND NCAA Regulations.

Vinyl Mesh Colors for Landing Areas, Weather Covers, and Base Protection Pads

